

This chapter describes the features of the logic array block (LAB) in the Arria® II core fabric. The LAB is composed of basic building blocks known as adaptive logic modules (ALMs) that you can configure to implement logic functions, arithmetic functions, and register functions.

This chapter contains the following sections:

- “Logic Array Blocks” on page 2-1
- “Adaptive Logic Modules” on page 2-5

Logic Array Blocks

Each LAB consists of ten ALMs, various carry chains, shared arithmetic chains, LAB control signals, local interconnect, and register chain connection lines. The local interconnect transfers signals between ALMs in the same LAB. The direct link interconnect allows the LAB to drive into the local interconnect of its left and right neighbors. Register chain connections transfer the output of the ALM register to the adjacent ALM register in the LAB. The Quartus® II Compiler places associated logic in the LAB or the adjacent LABs, allowing the use of local, shared arithmetic chain, and register chain connections for performance and area efficiency.

Figure 2-1 shows the Arria II LAB structure and the LAB interconnects.

Figure 2-1. LAB Structure in Arria II Devices

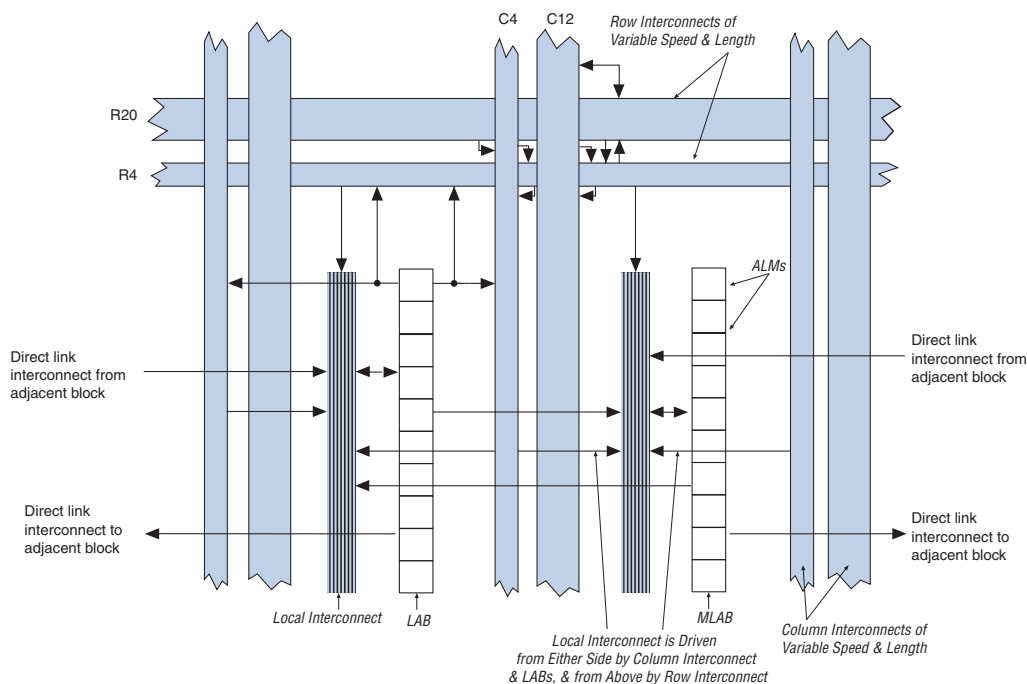

© 2010 Altera Corporation. All rights reserved. ALTERA, ARRIA, CYCLONE, HARDCOPY, MAX, MEGACORE, NIOS, QUARTUS and STRATIX are Reg. U.S. Pat. & Tm. Off. and/or trademarks of Altera Corporation in the U.S. and other countries. All other trademarks and service marks are the property of their respective holders as described at www.altera.com/common/legal.html. Altera warrants performance of its semiconductor products to current specifications in accordance with Altera's standard warranty, but reserves the right to make changes to any products and services at any time without notice. Altera assumes no responsibility or liability arising out of the application or use of any information, product, or service described herein except as expressly agreed to in writing by Altera. Altera customers are advised to obtain the latest version of device specifications before relying on any published information and before placing orders for products or services.

The LAB of the Arria II device has a derivative called memory LAB (MLAB), which adds look-up table (LUT)-based SRAM capability to the LAB. The MLAB supports a maximum of 640 bits of simple dual-port SRAM. You can configure each ALM in an MLAB as either a 64×1 or 32×2 block, resulting in a configuration of 64×10 or 32×20 simple dual-port SRAM blocks. MLAB and LAB blocks always coexist as pairs in Arria II devices. MLAB is a superset of the LAB and includes all LAB features.

Figure 2-2 shows an overview of LAB and MLAB topology.

 For more information about MLABs, refer to the *TriMatrix Memory Blocks in Arria II Devices* chapter.

Figure 2-2. LAB and MLAB Structure in Arria II Devices

LUT-based-64 x 1 ⁽¹⁾ Simple dual port SRAM	ALM
LUT-based-64 x 1 ⁽¹⁾ Simple dual port SRAM	ALM
LUT-based-64 x 1 ⁽¹⁾ Simple dual port SRAM	ALM
LUT-based-64 x 1 ⁽¹⁾ Simple dual port SRAM	ALM
LUT-based-64 x 1 ⁽¹⁾ Simple dual port SRAM	ALM
LAB Control Block	LAB Control Block
LUT-based-64 x 1 ⁽¹⁾ Simple dual port SRAM	ALM
LUT-based-64 x 1 ⁽¹⁾ Simple dual port SRAM	ALM
LUT-based-64 x 1 ⁽¹⁾ Simple dual port SRAM	ALM
LUT-based-64 x 1 ⁽¹⁾ Simple dual port SRAM	ALM
LUT-based-64 x 1 ⁽¹⁾ Simple dual port SRAM	ALM

MLAB **LAB**

Note to Figure 2-2:

(1) You can use an MLAB ALM as a regular LAB ALM or configure it as a dual-port SRAM.

LAB Interconnects

The LAB local interconnect drives the ALMs in the same LAB using column and row interconnects and the ALM outputs in the same LAB. The direct link connection feature minimizes the use of row and column interconnects, providing higher performance and flexibility. Adjacent LABs/MLABs, memory blocks, or DSP blocks from the left or right can also drive the LAB's local interconnect through the direct link connection. Each LAB can drive 30 ALMs through fast local and direct link interconnects. Ten ALMs are in any given LAB and ten ALMs are in each of the adjacent LABs.

Figure 2-3 shows the direct link connection, which connects adjacent LABs, memory blocks, DSP blocks, or I/O element (IOE) outputs.

Figure 2-3. Direct Link Connection

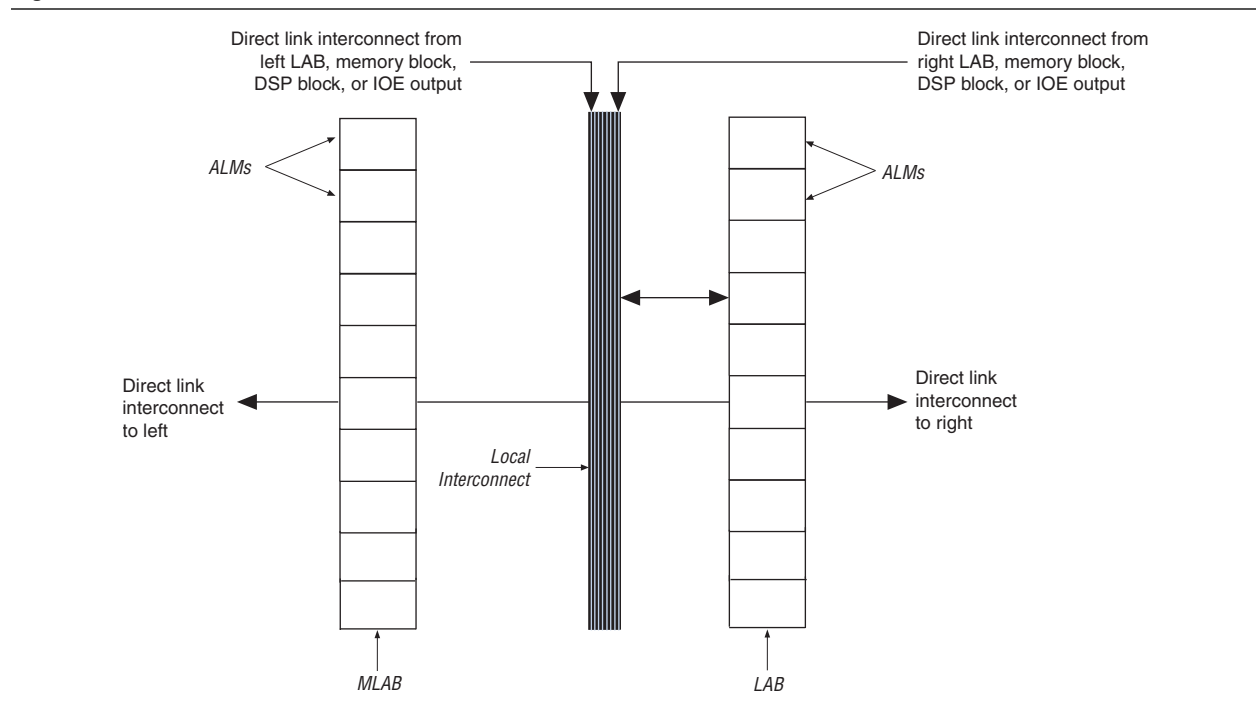

LAB Control Signals

Each LAB contains dedicated logic for driving a maximum of 10 control signals to its ALMs at a time. Control signals include three clocks, three clock enables, two asynchronous clears, a synchronous clear, and synchronous load control signals. Although you generally use synchronous-load and clear signals when implementing counters, you can also use them with other functions. Each LAB has two unique clock sources and three clock enable signals, as shown in Figure 2-4. The LAB control block can generate up to three clocks using two clock sources and three clock enable signals. Each clock and clock enable signals are linked. For example, any ALM in a particular LAB using the `labclk1` signal also uses the `labclkena1` signal. If the LAB uses both the rising and falling edges of a clock, it also uses two LAB-wide clock signals. De-asserting the clock enable signal turns off the corresponding LAB-wide clock. The LAB row clocks [5..0] and LAB local interconnects generate the LAB-wide control signals. In addition to data, the inherent low skew of the MultiTrack interconnect allows clock and control signal distribution.

Figure 2-4. LAB-Wide Control Signals

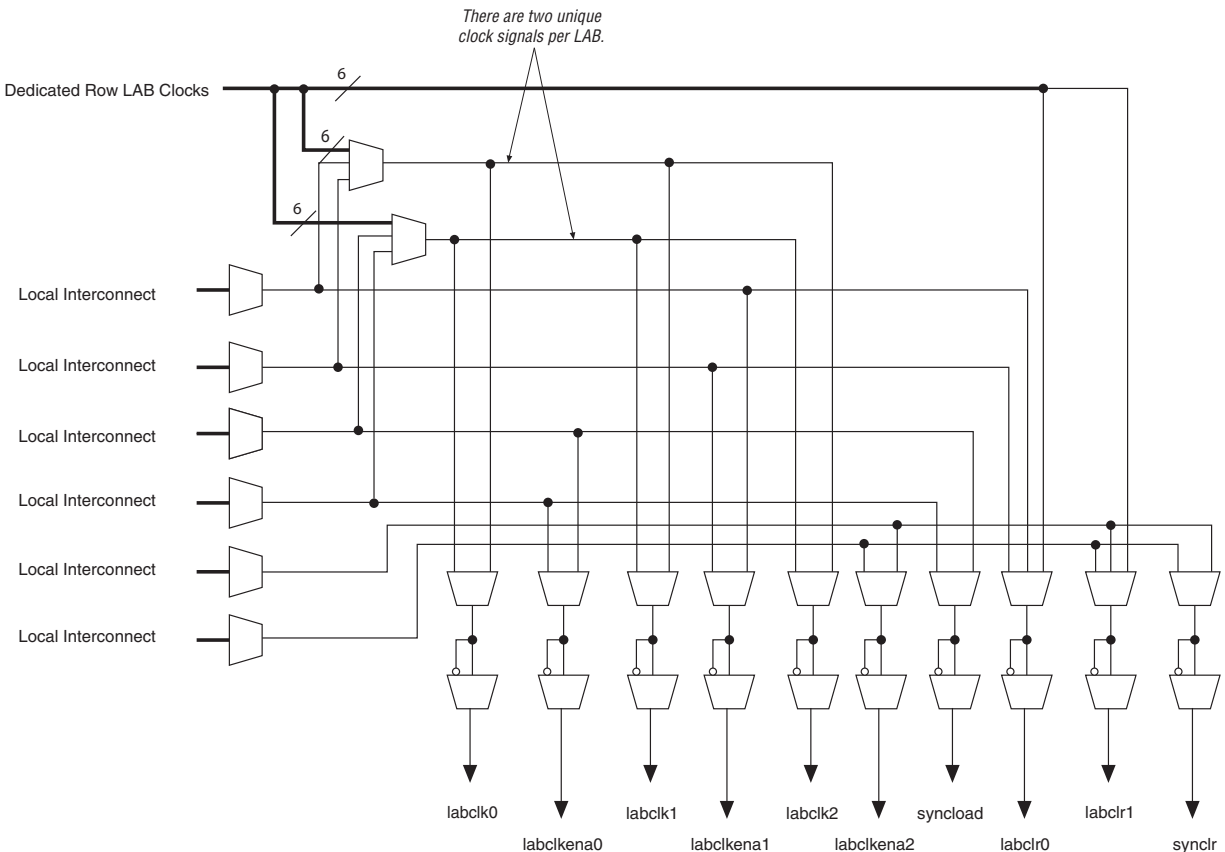

Adaptive Logic Modules

The ALM is the basic building block of logic in the Arria II device architecture. Each ALM contains a variety of LUT-based resources that can be divided between two combinational adaptive LUTs (ALUTs) and two registers. With up to eight inputs for the two combinational ALUTs, one ALM can implement various combinations of two functions. This adaptability allows an ALM to be completely backward-compatible with 4-input LUT architectures. One ALM can also implement any function with up to 6-input and certain 7-input functions. In addition to the ALUT-based resources, each ALM contains two programmable registers, two dedicated full adders, a carry chain, a shared arithmetic chain, and a register chain. Through these dedicated resources, an ALM can efficiently implement various arithmetic functions and shift registers. Each ALM drives all types of interconnects: local, row, column, carry chain, shared arithmetic chain, register chain, and direct link. Figure 2-5 shows a high-level block diagram of the Arria II ALM.

Figure 2-5. High-Level Block Diagram of the Arria II ALM

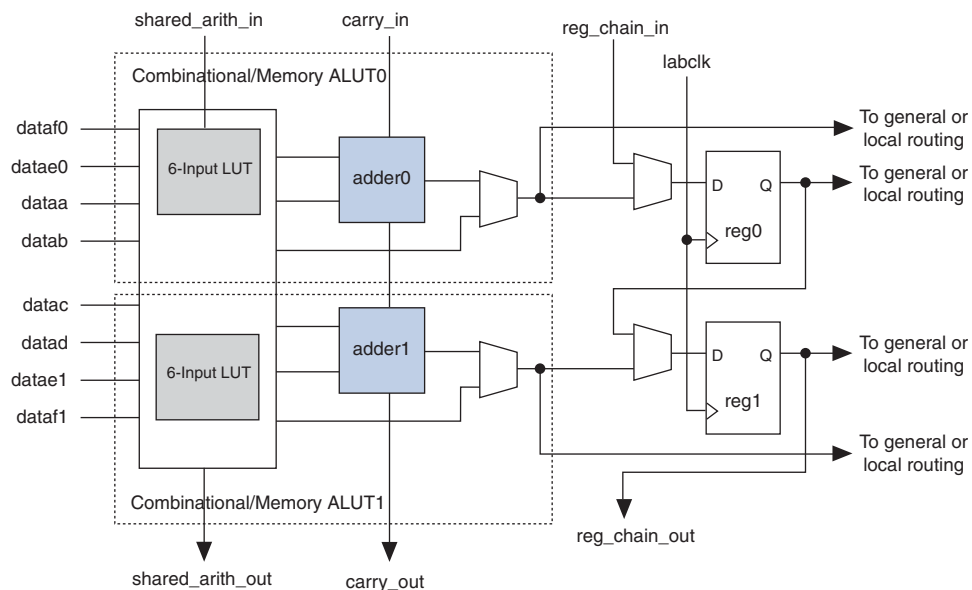
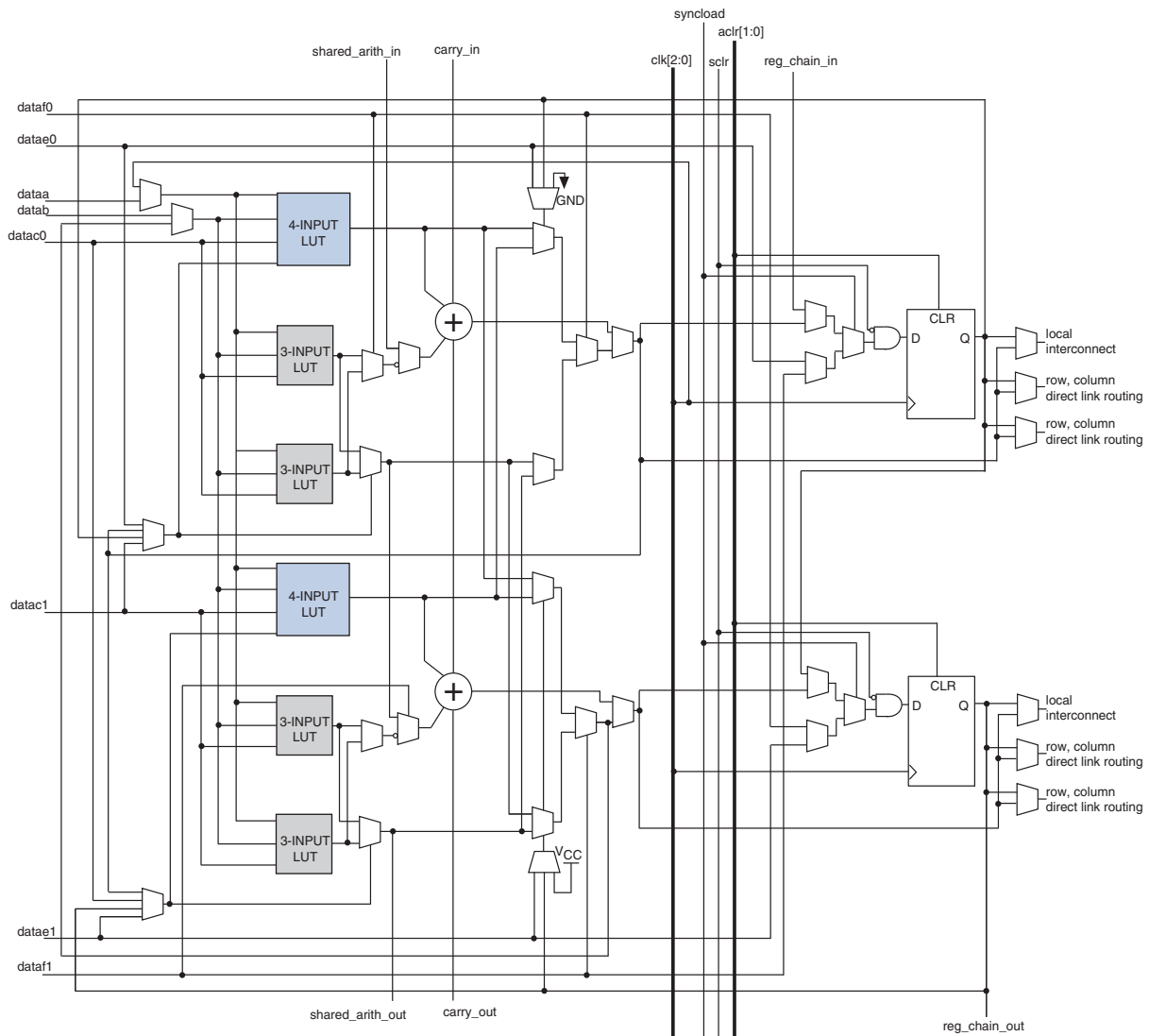

Figure 2-6 shows a detailed view of all the connections in an ALM.

Figure 2-6. Connection Details of the Arria II ALM



One ALM contains two programmable registers. Each register has data, clock, clock enable, synchronous and asynchronous clear, and synchronous load and clear inputs. Global signals, general purpose I/O (GPIO) pins, or any internal logic can drive the register's clock and clear-control signals. Either GPIO pins or internal logic can drive the clock enable. For combinational functions, the register is bypassed and the output of the LUT drives directly to the outputs of an ALM.

Each ALM has two sets of outputs that drive the local, row, and column routing resources. The LUT, adder, or register output can drive the ALM outputs (refer to Figure 2-6). For each set of output drivers, two ALM outputs can drive column, row, or direct link routing connections, and one of these ALM outputs can also drive local interconnect resources. The LUT or adder can drive one output while the register drives another output.

This feature is called register packing. It improves device utilization by allowing the device to use the register and combinational logic for unrelated functions. Another mechanism to improve fitting is to allow the register output to feed back into the LUT of the same ALM so that the register is packed with its own fan-out LUT. The ALM can also drive out registered and unregistered versions of the LUT or adder output.

The Quartus II software automatically configures the ALMs for optimized performance.

ALM Operating Modes

The Arria II ALM can operate in any of the following modes:

- Normal
- Extended LUT
- Arithmetic
- Shared Arithmetic
- LUT-Register

The Quartus II software and other supported third-party synthesis tools, in conjunction with parameterized functions such as the library of parameterized modules (LPM) functions, automatically choose the appropriate mode for common functions such as counters, adders, subtractors, and arithmetic functions. Each mode uses the ALM resources differently. In each mode, eleven available inputs to an ALM—the eight data inputs from the LAB local interconnect, carry-in from the previous ALM or LAB, the shared arithmetic chain connection from the previous ALM or LAB, and the register chain connection—are directed to different destinations to implement the desired logic function. LAB-wide signals provide clock, asynchronous clear, synchronous clear, synchronous load, and clock enable control for the register. These LAB-wide signals are available in all ALM modes. For more information on the LAB-wide control signals, refer to [“LAB Control Signals” on page 2-4](#).

Normal Mode

Normal mode is suitable for general logic applications and combinational functions. In this mode, up to eight data inputs from the LAB local interconnect are inputs to the combinational logic. Normal mode allows two functions to be implemented in one Arria II ALM, or a single function of up to six inputs. The ALM can support certain combinations of completely independent functions and various combinations of functions that have common inputs.

Figure 2-7 shows the supported LUT combinations in normal mode.

Figure 2-7. ALM in Normal Mode (Note 1)

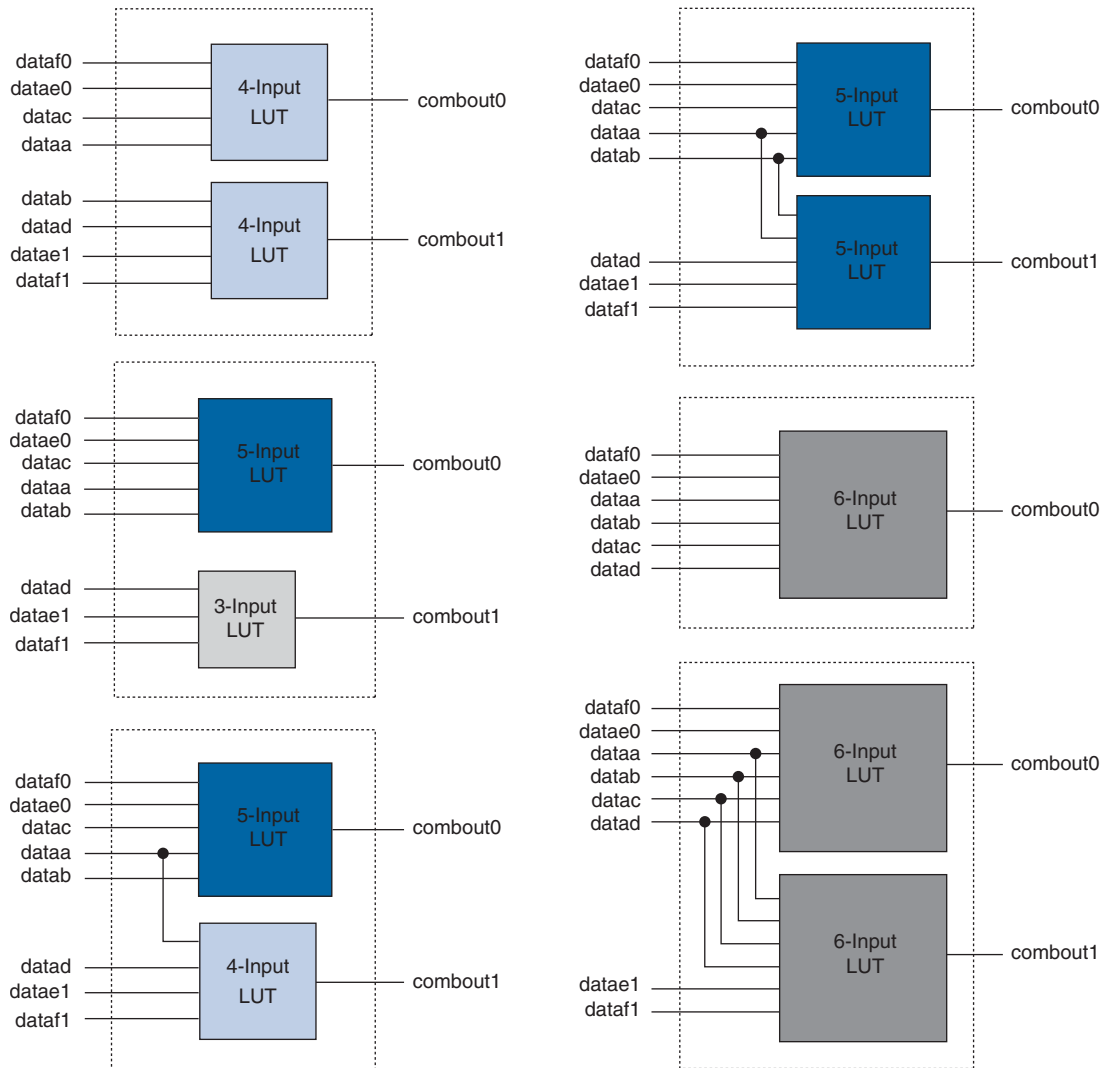

Note to Figure 2-7:

- (1) Combinations of functions with fewer inputs than those shown are also supported. For example, combinations of functions with the following number of inputs are supported: 4 and 3, 3 and 3, 3 and 2, and 5 and 2.

Normal mode provides complete backward-compatibility with 4-input LUT architectures.

For the packing of two 5-input functions into one ALM, the functions must have at least two common inputs. The common inputs are `dataa` and `datab`. The combination of a 4-input function with a 5-input function requires one common input (either `dataa` or `datab`).

In the case of implementing two 6-input functions in one ALM, four inputs must be shared and the combinational function must be the same. In a sparsely used device, functions that could be placed in one ALM may be implemented in separate ALMs by the Quartus II software to achieve the best possible performance. As a device begins to fill up, the Quartus II software automatically utilizes the full potential of the Arria II ALM. The Quartus II Compiler automatically searches for functions using common inputs or completely independent functions to be placed in one ALM to make efficient use of device resources. In addition, you can manually control resource usage by setting location assignments.

Any 6-input function can be implemented using inputs `dataa`, `datab`, `datac`, `datad`, and either `datae0` and `dataf0` or `datae1` and `dataf1`. If `datae0` and `dataf0` are utilized, the output is driven to `register0`, and/or `register0` is bypassed and the data drives out to the interconnect using the top set of output drivers (refer to [Figure 2-8](#)). If `datae1` and `dataf1` are used, the output either drives to `register1` or bypasses `register1` and drives to the interconnect using the bottom set of output drivers. The Quartus II Compiler automatically selects the inputs to the LUT. ALMs in normal mode support register packing.

Figure 2-8. Input Function in Normal Mode (Note 1)

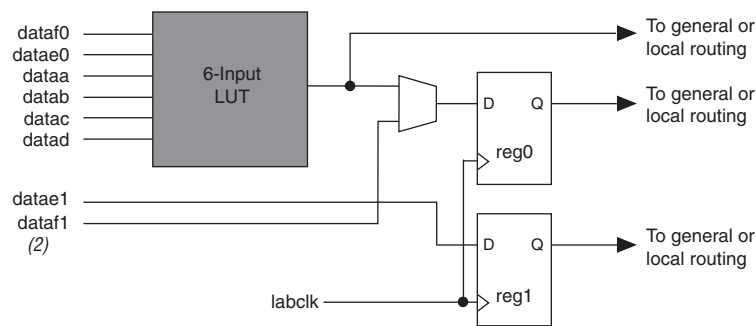

Notes to Figure 2-8:

- (1) If `datae1` and `dataf1` are used as inputs to a 6-input function, `datae0` and `dataf0` are available for register packing.
- (2) The `dataf1` input is available for register packing only if the 6-input function is unregistered.

Extended LUT Mode

Use extended LUT mode to implement a specific set of 7-input functions. The set must be a 2-to-1 multiplexer fed by two arbitrary 5-input functions sharing four inputs.

Figure 2-9 shows the template of supported 7-input functions using extended LUT mode. In this mode, if the 7-input function is unregistered, the unused eighth input is available for register packing.

Functions that fit into the template, as shown in Figure 2-9, often appear in designs as “if-else” statements in Verilog HDL or VHDL code.

Figure 2-9. Template for Supported 7-Input Functions in Extended LUT Mode

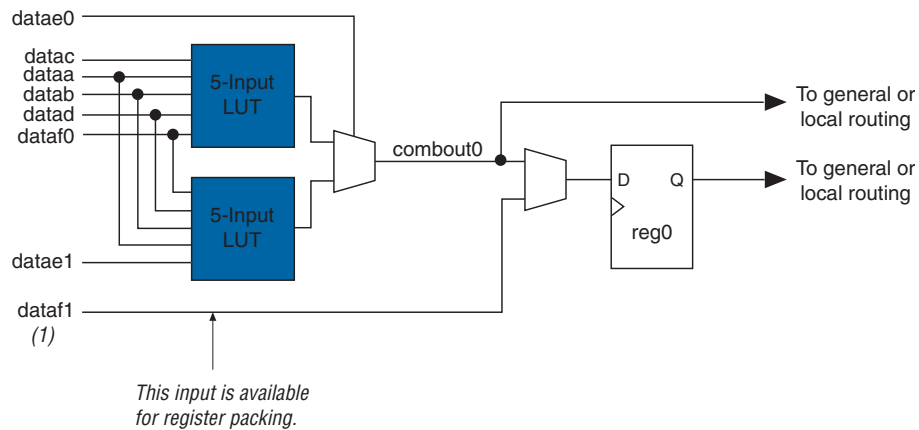

Note to Figure 2-9:

(1) If the 7-input function is unregistered, the unused eighth input is available for register packing. The second register, `reg1`, is not available.

Arithmetic Mode

Arithmetic mode is ideal for implementing adders, counters, accumulators, wide parity functions, and comparators. The ALM in arithmetic mode uses two sets of two 4-input LUTs along with two dedicated full adders. The dedicated adders allow the LUTs to be available to perform pre-adder logic; therefore, each adder can add the output of two 4-input functions. The four LUTs share dataa and datab inputs. As shown in Figure 2-10, the carry-in signal feeds to adder0 and the carry-out from adder0 feeds to the carry-in of adder1. The carry-out from adder1 drives to adder0 of the next ALM in the LAB. ALMs in arithmetic mode can drive out registered and unregistered versions of the adder outputs.

Figure 2-10. ALM in Arithmetic Mode

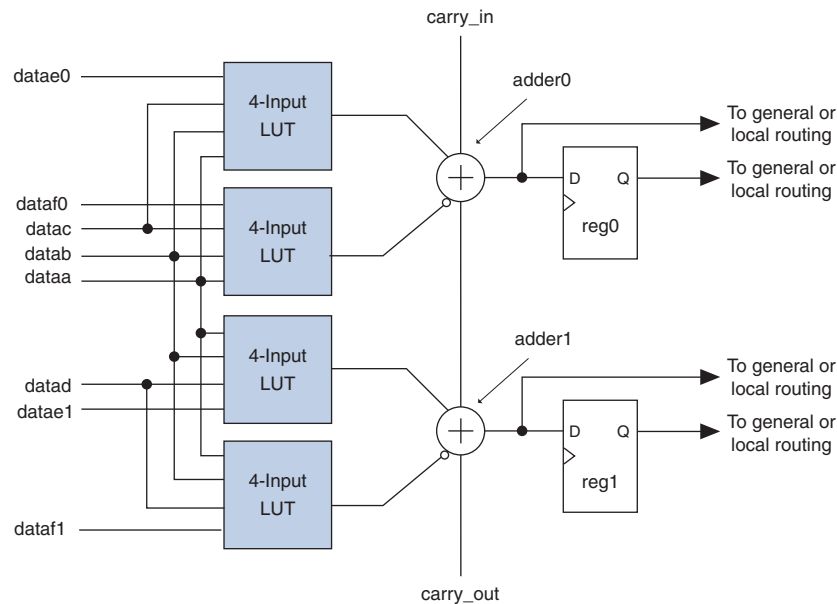

In arithmetic mode, the ALM supports simultaneous use of the adder's carry output along with combinational logic outputs. The adder output is ignored in this operation. Using the adder with combinational logic output provides resource savings of up to 50% for functions that can use this mode.

Arithmetic mode also offers clock enable, counter enable, synchronous up and down control, add and subtract control, synchronous clear, and synchronous load. The LAB local interconnect data inputs generate the clock enable, counter enable, synchronous up and down, and add and subtract control signals. These control signals are good candidates for the inputs that share the four LUTs in the ALM. The synchronous clear and synchronous load options are LAB-wide signals that affect all registers in the LAB. These signals can also be individually disabled or enabled per register. The Quartus II software automatically places any registers that are not used by the counter into other LABs.

Carry Chain

The carry chain provides a fast carry function between the dedicated adders in arithmetic or shared arithmetic mode. The two-bit carry select feature in Arria II devices halves the propagation delay of carry chains within the ALM. Carry chains can begin in either the first ALM or the fifth ALM in a LAB. The final carry-out signal is routed to an ALM, where it is fed to local, row, or column interconnects.

The Quartus II Compiler automatically creates carry chain logic during design processing, or you can create it manually during design entry. Parameterized functions such as LPM automatically take advantage of carry chains for the appropriate functions.

The Quartus II Compiler creates carry chains longer than 20 ALMs (10 ALMs in arithmetic or shared arithmetic mode) by linking LABs together automatically. To enhance fitting, a long carry chain runs vertically, allowing fast horizontal connections to TriMatrix memory and DSP blocks. A carry chain can continue as far as a full column.

To avoid routing congestion in one small area of the device when a high fan-in arithmetic function is implemented, the LAB can support carry chains that only use either the top half or bottom half of the LAB before connecting to the next LAB. This leaves the other half of the ALMs in the LAB available for implementing narrower fan-in functions in normal mode. Carry chains that use the top five ALMs in the first LAB carry into the top half of the ALMs in the next LAB in the column. Carry chains that use the bottom five ALMs in the first LAB carry into the bottom half of the ALMs in the next LAB within the column. In every alternate LAB column, the top half can be bypassed; in the other MLAB columns, the bottom half can be bypassed.



For more information on carry chain interconnect, refer to [“ALM Interconnects”](#) on page 2-17.

Shared Arithmetic Mode

In shared arithmetic mode, the ALM can implement a 3-input add in an ALM. In this mode, the ALM is configured with four 4-input LUTs. Each LUT either computes the sum of three inputs or the carry of three inputs. The output of the carry computation is fed to the next adder using a dedicated connection called the shared arithmetic chain. This shared arithmetic chain can significantly improve the performance of an adder tree by reducing the number of summation stages required to implement an adder tree. Figure 2-11 shows the ALM using this feature.

Figure 2-11. ALM in Shared Arithmetic Mode

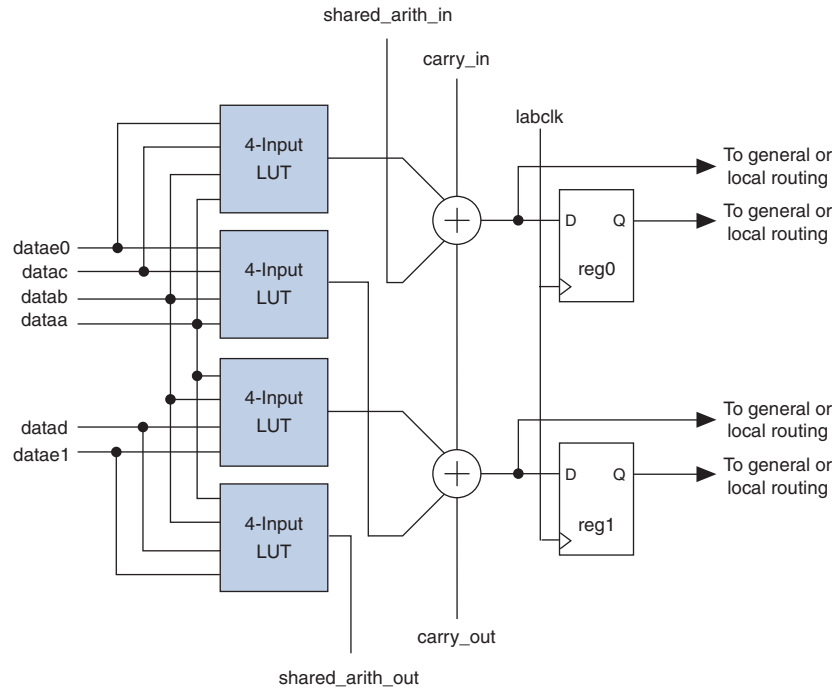

You can find adder trees in many different applications. For example, the summation of the partial products in a logic-based multiplier can be implemented in a tree structure. Another example is a correlator function that can use a large adder tree to sum filtered data samples in a given time frame to recover or de-spread data that was transmitted using spread-spectrum technology.

Shared Arithmetic Chain

The shared arithmetic chain available in enhanced arithmetic mode allows the ALM to implement a 3-input add. This significantly reduces the resources necessary to implement large adder trees or correlator functions.

The shared arithmetic chains can begin in either the first or sixth ALM in an LAB. The Quartus II Compiler creates shared arithmetic chains longer than 20 ALMs (10 ALMs in arithmetic or shared arithmetic mode) by linking LABs together automatically. To enhance fitting, a long shared arithmetic chain runs vertically, allowing fast horizontal connections to the TriMatrix memory and DSP blocks. A shared arithmetic chain can continue as far as a full column.

Similar to the carry chains, the top and bottom half of shared arithmetic chains in alternate LAB columns can be bypassed. This capability allows the shared arithmetic chain to cascade through half of the ALMs in an LAB while leaving the other half available for narrower fan-in functionality. Every other LAB column is top-half bypassable, while the other LAB columns are bottom-half bypassable.



For more information on shared arithmetic chain interconnect, refer to [“ALM Interconnects” on page 2-17](#).

LUT-Register Mode

LUT-Register mode allows third register capability in an ALM. Two internal feedback loops allow combinational ALUT1 to implement the master latch and combinational ALUT0 to implement the slave latch needed for the third register. The LUT register shares its clock, clock enable, and asynchronous clear sources with the top dedicated register. Figure 2-12 shows the register constructed using two combinational blocks in the ALM.

Figure 2-12. LUT Register from Two Combinational Blocks

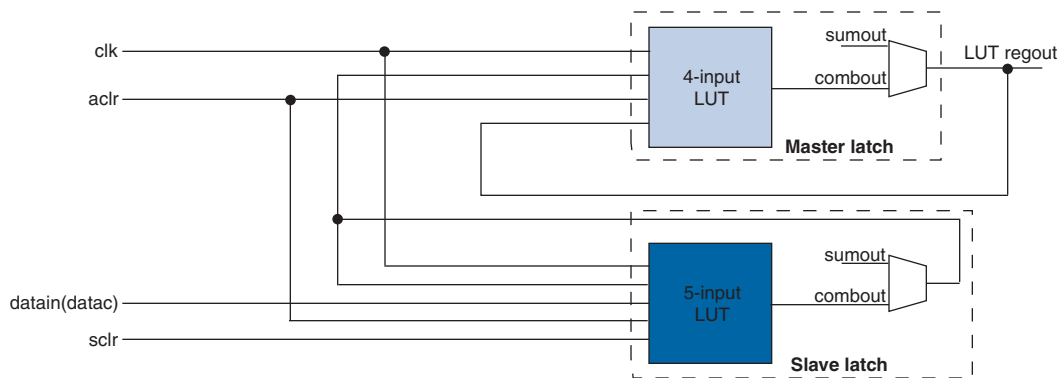
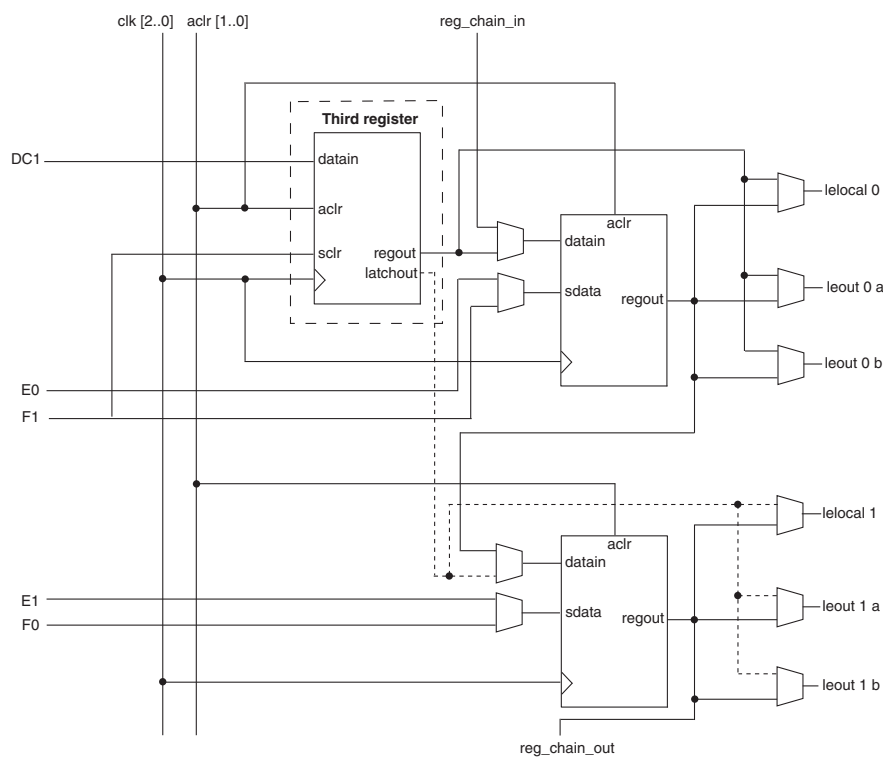

Figure 2-13 shows the ALM in LUT-Register mode.

Figure 2-13. ALM in LUT-Register Mode with 3-Register Capability



Register Chain

In addition to general routing outputs, the ALMs in any given LAB have register chain outputs to allow registers in the same LAB to be cascaded together. The register chain interconnect allows a LAB to use LUTs for a single combinational function and the registers to be used for an unrelated shift register implementation. These resources speed up connections between ALMs while saving local interconnect resources (refer to Figure 2-14). The Quartus II Compiler automatically takes advantage of these resources to improve utilization and performance.

Figure 2-14. Register Chain in an LAB (Note 1)

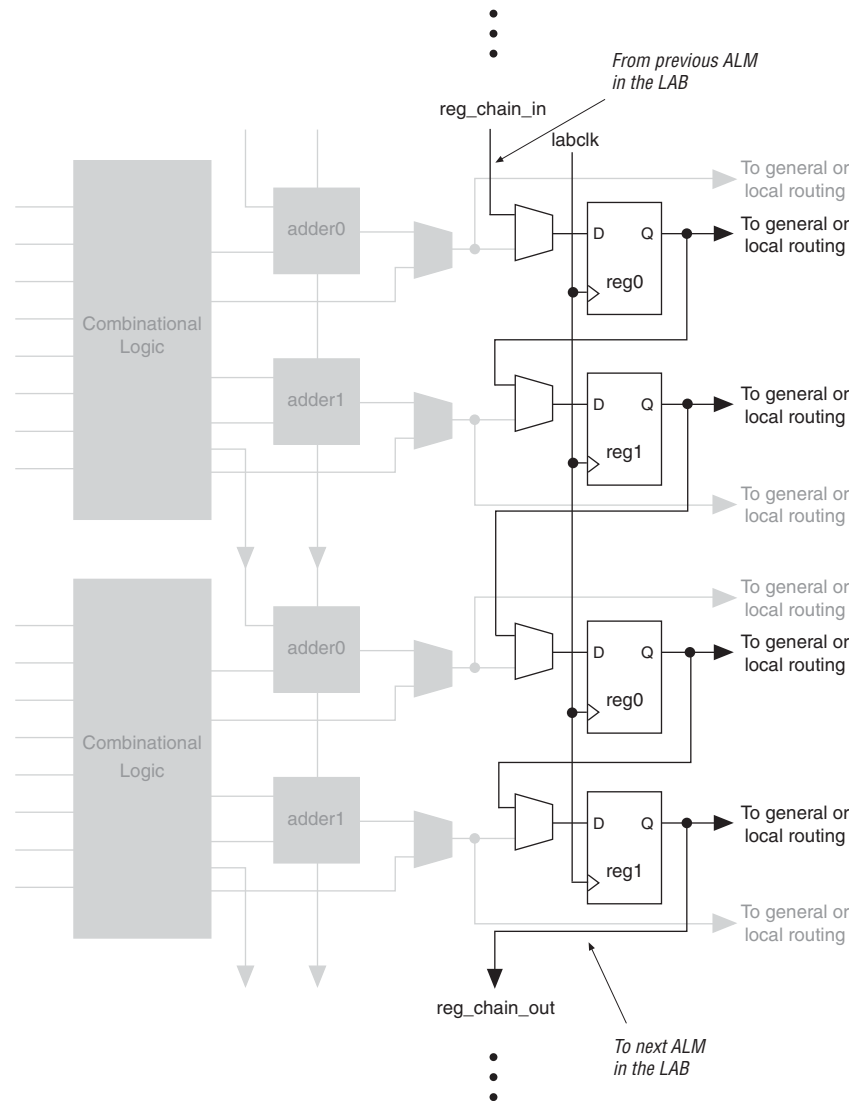

Note to Figure 2-14:

(1) You can use the combinational or adder logic to implement an unrelated, un-registered function.



For more information about register chain interconnect, refer to “ALM Interconnects” on page 2-17.

ALM Interconnects

There are three dedicated paths between ALMs: Register Cascade, Carry-chain, and Shared Arithmetic chain. Arria II devices include an enhanced interconnect structure in LABs for routing shared arithmetic chains and carry chains for efficient arithmetic functions. The register chain connection allows the register output of one ALM to connect directly to the register input of the next ALM in the LAB for fast shift registers. These ALM-to-ALM connections bypass the local interconnect. Figure 2-15 shows the shared arithmetic chain, carry chain, and register chain interconnects.

Figure 2-15. Shared Arithmetic Chain, Carry Chain, and Register Chain Interconnects

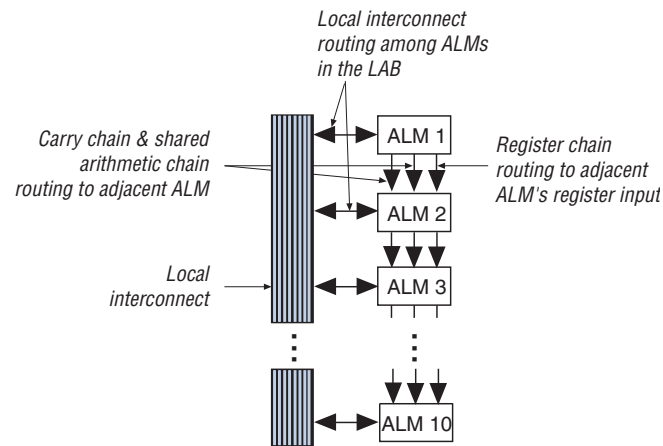

Clear and Preset Logic Control

LAB-wide signals control the logic for the register's clear signal. The ALM directly supports an asynchronous clear function. You can achieve the register preset through the Quartus II software's NOT-gate push-back logic option. Each LAB supports up to two clears.

Arria II devices provide a device-wide reset pin (DEV_CLR_n) that resets all registers in the device. An option set before compilation in the Quartus II software enables this pin. This device-wide reset overrides all other control signals.

LAB Power Management Techniques

The following techniques are used to manage static and dynamic power consumption within the LAB:

- The Quartus II software forces all adder inputs low when ALM adders are not in use to save AC power.
- Arria II LABs operate in high-performance mode or low-power mode. The Quartus II software automatically chooses the appropriate mode for the LAB, based on the design, to optimize speed versus leakage trade-offs.

- Clocks represent a significant portion of dynamic power consumption due to their high switching activity and long paths. The LAB clock that distributes a clock signal to registers within an LAB is a significant contributor to overall clock power consumption. Each LAB's clock and clock enable signal are linked. For example, a combinational ALUT or register in a particular LAB using the `labclk1` signal also uses the `labckena1` signal. To disable an LAB-wide clock power consumption without disabling the entire clock tree, use the LAB-wide clock enable to gate the LAB-wide clock. The Quartus II software automatically promotes register-level clock enable signals to the LAB-level. All registers within the LAB that share a common clock and clock enable are controlled by a shared, gated clock. To take advantage of these clock enables, use a clock-enable construct in your HDL code for the registered logic.

 For more information about implementing static and dynamic power consumption within the LAB, refer to the *Power Optimization* chapter in volume 2 of the *Quartus II Handbook*.

Document Revision History

Table 2-1 lists the revision history for this document.

Table 2-1. Document Revision History

Date	Version	Changes
December 2010	2.0	Updated for the Quartus II software version 10.1 release: <ul style="list-style-type: none"> ■ Added Arria II GZ device information. ■ Updated “Logic Array Blocks”, “LAB Interconnects”, “LAB Control Signals”, “Adaptive Logic Modules”, “ALM Operating Modes”, “Normal Mode” sections. ■ Added Figure 2-7 and Figure 2-8. ■ Added “LAB Power Management Techniques” section.
June 2009	1.1	Updated Figure 2-6.
February 2009	1.0	Initial Release.